

10 START THE INSTALLATION AT THE BOTTOM STEP AND PROCEED UPWARDS

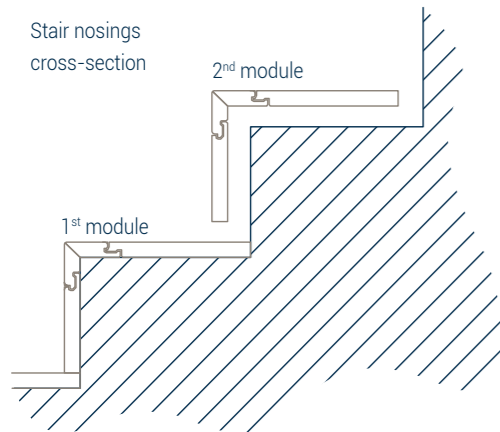

Installing the final step

For floating installation upstairs you should use top stair nosing.

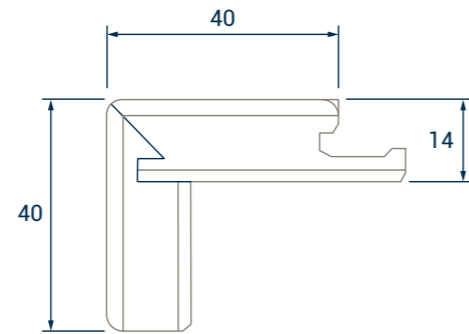

Use Tarkett Parquet Adhesive D or MS (depending on subconstruction) to glue down each module, applying the adhesive to the step and spreading it with a trowel.

Apply construction adhesive to the riser and ends of each step to hold the module in place.

After applying the glue, position the glued module and press it on to the wood or concrete surface of both step and riser.

The glueing process is best undertaken at the end of the working day to minimise walking on the stairs while they are drying.

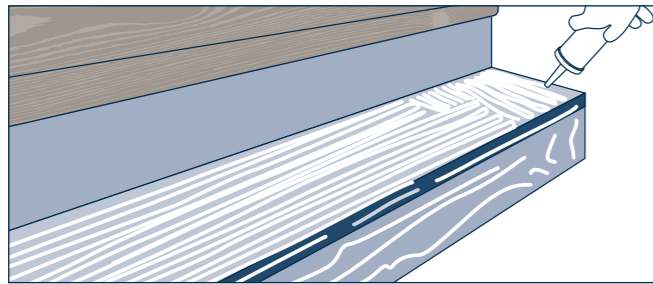

Ensure the steps lie perfectly flat.



The final stair nosing should be glued to the top step, not the riser below it.

Keep a gap of 8 mm between riser and stair nosing during installation.

The top of the riser should be level with the subfloor of the top step.

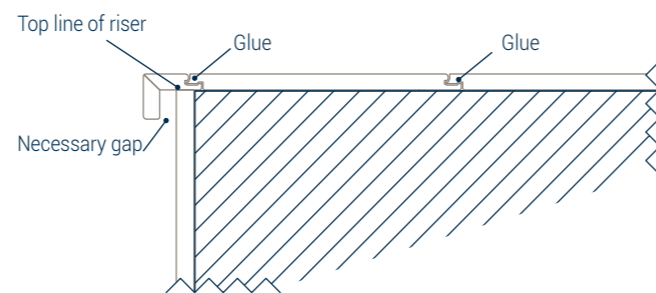

For the final touch: to give your installation the finishing touch, we recommend our hardwax oiled floor repair kit.

Maintenance: As our stair nosings are made from the same material as our wooden floors, see the data sheet of the relevant floor for maintenance details.

Floating installation: See separate installation instructions.

All available at www.tarkett.com

Stair nosing solutions

TARKETT WOOD - INSTALLATION INSTRUCTIONS

The new collection of stair nosings coordinated with our exclusive wood decors

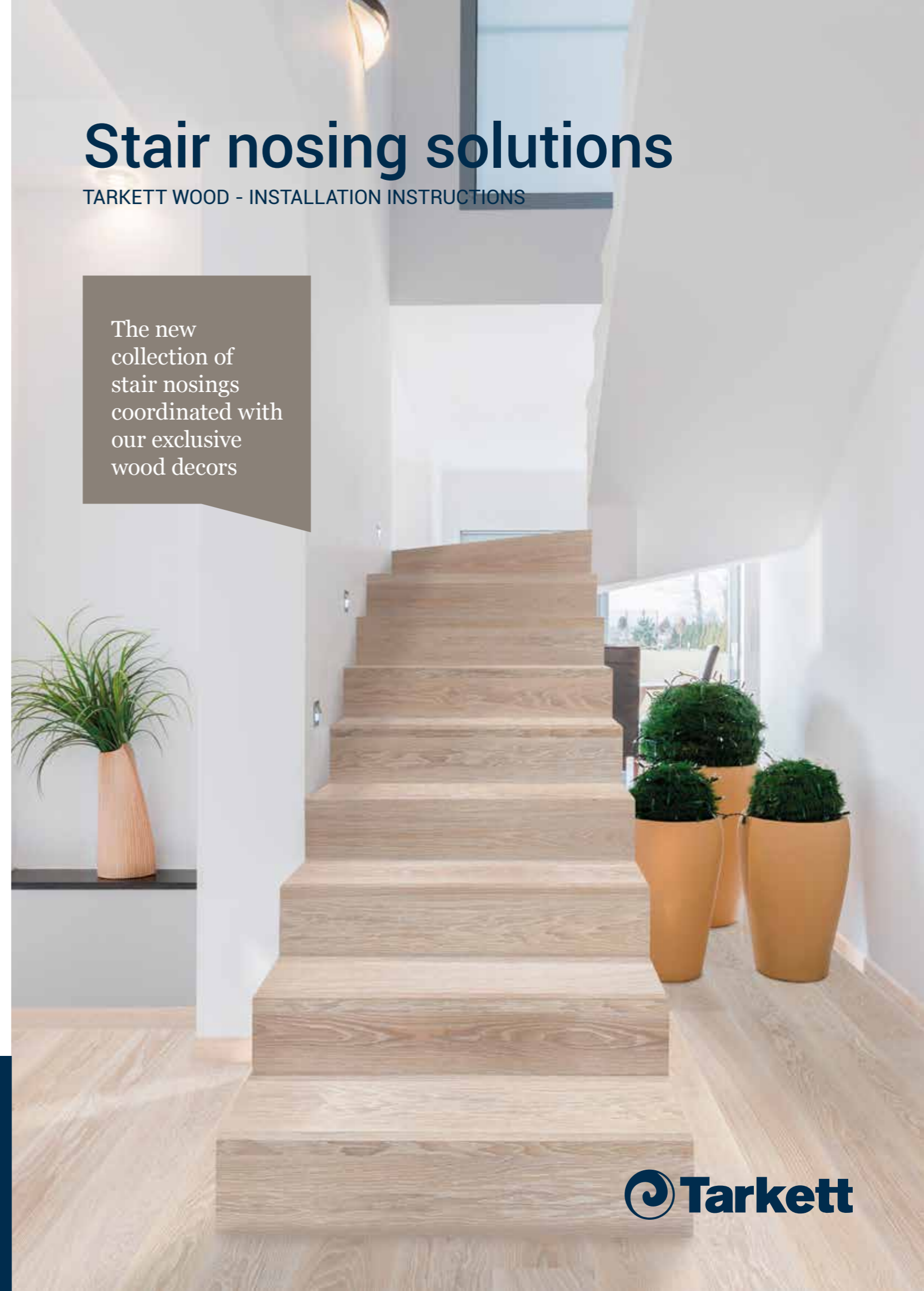

01/2018

Tarkett Group

Head Office
1 Terrasse Bellini - Tour Initiale
92919 Paris La defense - France

www.tarkett.com

■ **WESTERN EUROPE:** Austria: Tarkett Holding GmbH, Niederlassung Wien - Tel. +43 1 47 88 062 • Belgium: Tarkett Belux Sprl - Tel. +32 16 35 98 80 • Denmark: Tarkett A/S - Tel. +45 43 90 60 11 • Finland: Tarkett Oy - Tel. +358 9 4257 9000 • France: Tarkett SAS - Tel. +33 1 41 20 42 49 • Germany: Tarkett Holding GmbH, Bereich Objekt - Tel. +49 62 33 810 • Greece: Tarkett Monoprosopi Ltd - Tel. +30 210 6745 340 • Italy: Tarkett S.p.A. - Tel. +39 0744 7551 • Luxembourg: Tarkett GDL SA - Tel. +352 949 211 8804 • Netherlands: Tarkett Holding GmbH, Vestiging Nederland - Tel. +31 416 685 491 • Norway: Tarkett AS - Tel. +47 32 20 92 00 • Portugal: Tarkett SA - Tel. +351 21 427 64 20 • Spain: Tarkett Floors S.L. - Tel. +34 91 358 00 35 • Sweden: Tarkett Sverige AB - Tel. +46 771 25 19 00 • Switzerland: Tarkett Holding GmbH, Bereich Objekt Schweiz - Tel. +41 043 233 79 24 • Turkey: Tarkett Aspen - Tel. +90 212 213 65 80 • United Kingdom: Tarkett Ltd - Tel. +44 (0) 1622 854 040 ■ **EASTERN EUROPE:** Baltic Countries: Tarkett Baltics: Tel. +370 37 262 220 • Czech Republic: Tarkett org. s.r.o. - Tel. +420 271 001 600 • Hungary: Tarkett Polska SP. Z. O. O. magyarországi fióktelepe - Tel. +36 1 437 8150 • Poland: Tarkett Polska Sp. z o. o. - Tel. +48 22 16 09 231 • Russian Federation: ZAO Tarkett RUS - Tel. +7 495 775 3737 • Slovakia: Tarkett Polska, organizačná zložka - Tel. +421 2 48291 317 • South East Europe: Tarkett SEE - Tel. +381 21 7557 649 (44) 569 12 21 • Ukraine: Tarkett UA - Tel. +38 (0) 44 569 12 21 ■ **ASIA AND OCEANIA:** Australia: Tarkett Australia Pty Ltd - Tel. +61 2 88 53 12 00 • China: Tarkett Floor Covering (Shanghai) Co. Ltd. - Tel. +86 (21) 60 95 68 38 ext 841 • North East Asia: Tarkett Hong Kong Limited - Tel. +852 2511 8716 • India: Tarkett France (India Branch) - Tel. +91 11 4352 4073 • South East Asia: Tarkett Flooring Singapore Pte. Ltd. - Tel. +65 6346 1585 ■ **AFRICA:** Tarkett International: Tel. +33 1 41 20 41 01 ■ **MIDDLE EAST:** Tarkett Middle East: Tel. +961 1 51 3363/4 • Israel: Tarkett International: Tel. +33 1 41 20 41 01 ■ **NORTH AMERICA:** USA: Tarkett Inc. - Tel. +1 713 869 5811 / Johnsonite - Tel. +1 440 543 8916 • Canada: Tarkett Inc. - Tel. +1 450 293 173 ■ **LATIN AMERICA:** Brazil: Tarkett - Tel. 55 12 3954 7108 • Argentina - Chile - Uruguay: Tarkett Latam Mercosur - Tel. +54 11 47 08 07 72 / +54 9 11 44 46 88 82 • Bolivia - Colombia - Ecuador - Panama - Paraguay - Peru - Trinidad and Tobago - Venezuela: Tarkett - Tel. +55 11 9 8410 9310 / +55 11 95494 0069 • Mexico/Central America: Tarkett Latam Mexico - Tel. +55 11 98410 9310

 **Tarkett**

1 SUBFLOOR TYPES

- wood construction
- concrete

2 EQUIPMENT REQUIRED

- trowel, Tarkett no. 8790211
- circular saw with guide rail
- sliding compound mitre saw
- handsaw
- jigsaw
- hammer
- ruler
- try square
- pen
- chisel

3 CONDITIONS

The subfloor must be level, sound, dry and clean

The relative air humidity (RH) must be between 30% and 60% and the temperature must be at least 18°C before, during and after installation. As moisture may appear in a new building, the stair nosings should be heated and aired in good time before installation, so that the right indoor climate is achieved.

Wooden floors and stair nosings should be stored under the same climatic conditions as above and not directly on/against concrete. The packs must not be opened until immediately before installation.

For floating installations the upstairs floor must be free to move with changes in temperature and humidity. It must not be anchored by heavier objects, such as kitchen interiors, fireplaces or heavy cabinets.

4 GLUE

- For wood sub construction: use Tarkett Parquet Adhesive D (no. 8790102) or construction adhesive for glueing down.
- For concrete sub construction: Tarkett Parquet Adhesive MS (no. 8790109) or construction adhesive
- For glueing tongue and groove: -Tarkett White PVAc Glue for Woodfloors D3 (no. 8790100)

5 STAIR NOSINGS AND BOARDS

The wear layer of plank comprises a single, broad strip of wood and colour differences between boards sometimes occur. To prevent wide variations in shade between stair nosings and surrounding boards, please first open the packs and sort the components into groups of similar colours. This will enable a transition to be achieved during installation, with no significant contrasts in tone.

Stair nosings can only be used in conjunction with boards of 14 mm thickness.

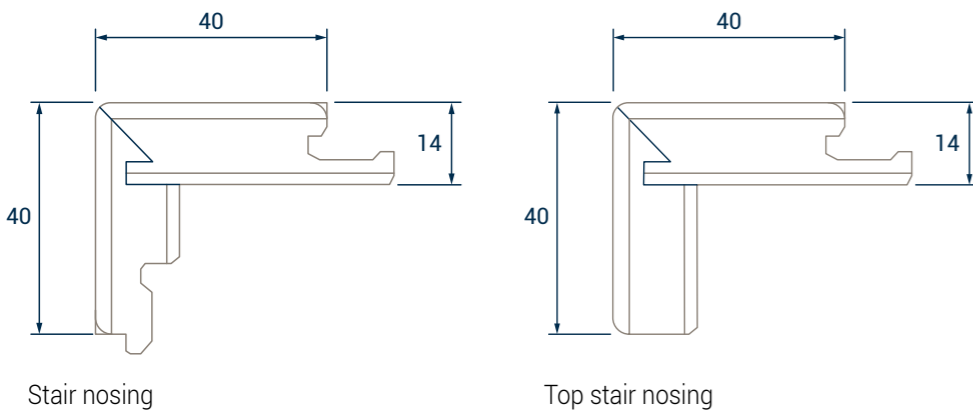

6 MEASUREMENT

To get the right shape of step you should use special equipment. The adjustable frame shown below can easily be adapted to fit the step's shape, enabling the outline to be traced on to the board.



7 RISER WIDTH

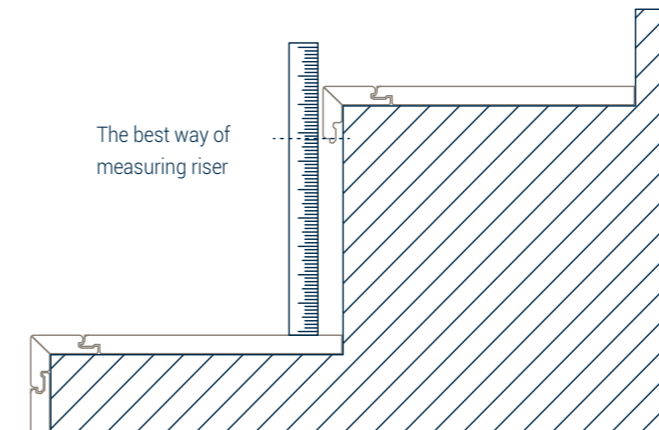

8 CUTTING

The best way to cut steps is using a circular saw with a guide rail.

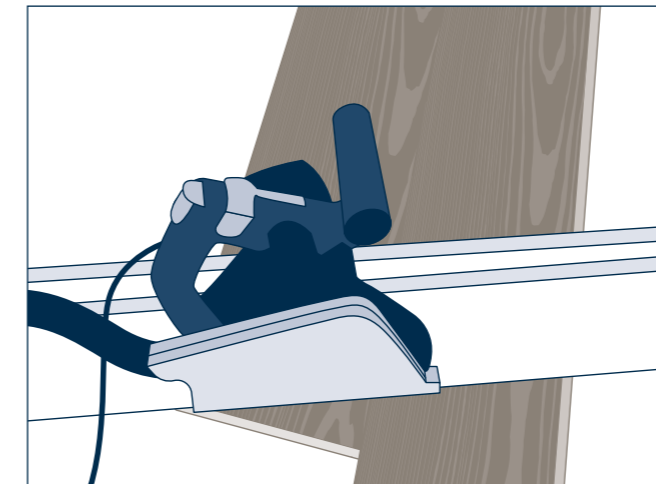

9 MAKING A MODULE

Make up an individual stair module from two boards and a stair nosing, applying glue to the edges of each piece.

For glueing, use Tarkett White PVAc Woodfloor Glue D3 (no. 8790100)

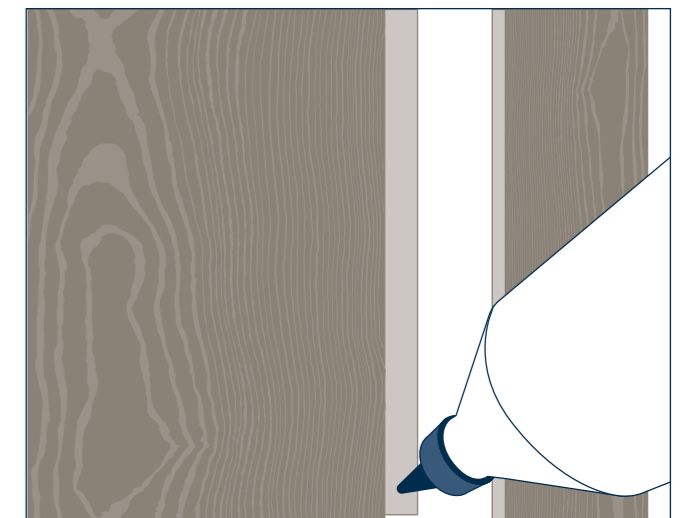
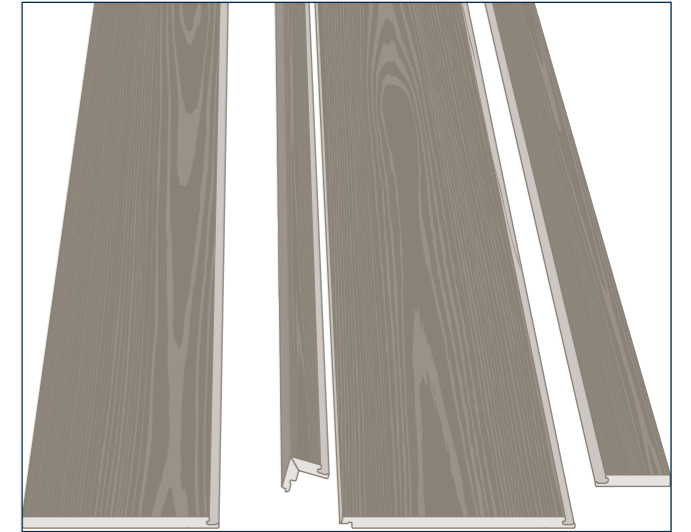

Take care to maintain a 90° angle between riser and step. The glued module is now ready to be installed.